

Planar Manipulation on a Conveyor with a One Joint Robot

Srinivas Akella Wesley H. Huang Kevin M. Lynch Matthew T. Mason

The Robotics Institute
Carnegie Mellon University

Abstract

This paper explores a method of manipulating a planar rigid body on a conveyor belt using a robot with just one joint. This approach has the potential of offering a simple and flexible method for feeding parts in industrial automation applications. In this paper we outline our approach, develop some of the theoretical properties, present a planner for the robot, and describe an initial implementation.

1 Introduction

The most straightforward approach to planar manipulation is to use a rigid grasp and a robot with at least three joints, corresponding to the three motion freedoms of a planar rigid object. But three joints are not really necessary to manipulate an object in the plane. In this paper we achieve effective control of all three planar motion freedoms using a one joint robot working over a constant speed conveyor belt.

A central issue in this work is to develop a precise notion of “effective control” that is suited to the parts-feeding application. Our robot cannot impart arbitrary motions to a part on the conveyor, but it does have a set of actions sufficient to orient and position a wide class of shapes. To make this precise we define the *feeding property*:

A system has the *feeding property* over a set of parts P and set of initial configurations I if, given any part in P , there is some output configuration \mathbf{q} such that the system can move the part to \mathbf{q} from any location in I .

One of the goals of this paper is to demonstrate that a one joint robot can possess this property over a useful set of initial configurations and a broad class of part shapes.

The key to our approach is to use a single revolute joint to push the parts around on a constant speed conveyor belt. This approach, which we refer to as

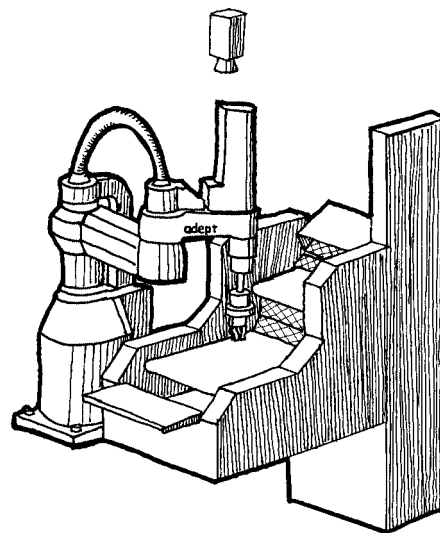

Figure 1: The Adept Flex Feeder System. A SCARA robot picks parts off the middle of three conveyors. These three conveyors, along with an elevator bucket, circulate parts; an overhead camera looks down on the back-lit middle conveyor to determine the position and orientation of parts.

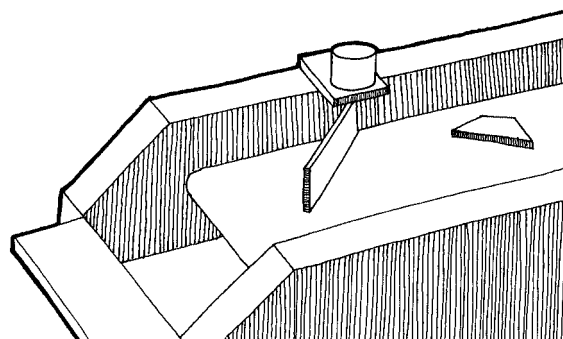

Figure 2: The Flex Feeder with a rotatable fence.

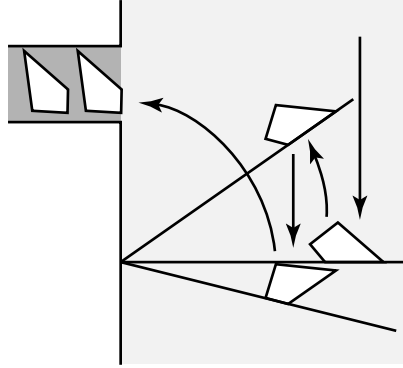

Figure 3: We can feed a part by alternately pushing it with the fence and letting it drift along the conveyor.

“1JOC” (one-joint-over-conveyor, pronounced “one jock”) was initially conceived as a variation on the Adept Flex Feeder (see Figure 1). The Flex Feeder uses a system of conveyors to recirculate parts, presenting them with random orientation to a camera and robotic manipulator. Those parts that are in a graspable configuration may then be picked up by the robot and assembled into a product, placed in a pallet, or otherwise processed.

The question addressed in this paper is whether, at least in parts feeding applications, we could replace the SCARA robot with a simpler and more flexible robot, and also replace the Flex Feeder’s servoed programmable conveyor with a fixed speed conveyor. Figures 2 and 3 show a possible variation on the Flex Feeder, where the SCARA robot has been replaced by a fence with a single revolute joint. By a sequence of pushing operations, punctuated by drift along the conveyor, the fence positions and orients a part and directs it into the entry point of a feeder track which carries the part to the next station.

There are many variations on this basic idea: a 2JOC, multiple 1JOCs working in parallel, curved fences, and so on. However, the purpose of this paper is an initial study of the fundamental characteristics of the idea, so we will focus on the simplest version as described above and in Figures 2 and 3. The main result is:

It is possible to move an arbitrary polygon from a broad range of initial configurations to a specific goal; and that goal can be chosen from a broad range of possible goals. (This is a generalization of the feeding property.)

The remainder of the paper is organized as follows. After reviewing previous work and terminology from nonlinear control theory, we develop a progression of models leading to the 1JOC. We prove the feeding

property for the 1JOC model and describe the implementation of a planner as well as experimental results.

1.1 Previous Work

The 1JOC approach described in this paper is an example of using a simple effector to perform nonprehensile manipulation. For a survey of work in this area, see (Erdmann [19]). Of particular relevance to this paper is previous work on parts feeding and the control of underactuated systems.

Parts Feeding Our goal is to develop parts feeders with practical use in industry. To realize this goal, we must study the parts feeding systems that have already found success in industry. Boothroyd *et al.* [8] describe parts feeding and orienting devices for automated assembly, including bowl feeders. Some recent work has focused on automating the design of bowl feeders (Boothroyd [9]; Caine [14]; Christiansen *et al.* [16]).

Another highly successful system is the SONY APOS system (Hitakawa [21]). Like a bowl feeder, the APOS system relies on vibration and shape to orient parts. Brost [13] demonstrates the use of shape alone to orient a part by dropping it on a specially designed nest.

Often, parts feeders that rely on shape are specific to a particular part or set of parts. Many researchers have studied constraint surfaces with simple shapes to handle a variety of parts. Examples of this include orienting parts by fences suspended over a conveyor (Peshkin and Sanderson [29]; Brokowski *et al.* [12]); translational pushing by a fence (Mani and Wilson [26]; Akella and Mason [1]); parallel-jaw grasping (Goldberg [20]); tray-tilting (Erdmann and Mason [18]; Christiansen [15]); vibrating a supporting plate (Böhringer *et al.* [6]; Swanson *et al.* [33]); and pushing by arrays of electromechanical manipulators (Böhringer *et al.* [7]).

Underactuated Systems The 1JOC is an underactuated system with a drift field. Such systems have been heavily studied in nonlinear control theory; see, for instance, (Brockett [11]; Crouch [17]). A good introduction to nonlinear control is given by Nijmeijer and van der Schaft [27].

Other examples of manipulation by an underactuated effector include slipping and rolling within a grasp (Bicchi and Sorrentino [5]; Brock [10]; Rao *et al.* [30]) and dynamic tasks such as snatching, rolling, and throwing (Arai and Khatib [3]; Lynch and Mason [25]).

The 1JOC can be likened to an underactuated manipulator in a gravity field, where the proximal “shoul-

der” (fence pivot) is directly actuated, but the distal degrees of freedom (represented by the object) are not. Research on the controllability of such serial link manipulators has been carried out by Oriolo and Nakamura [28] and Arai and Tachi [2]. Sjørdalen *et al.* [31] recently developed a nonholonomic gear which allowed them to construct a controllable n -link planar arm with only two motors.

1.2 Terminology

The 1JOC has only one controlled degree-of-freedom, yet we would like to control three degrees-of-freedom of a part on the conveyor — the system is underactuated. The natural question is whether the 1JOC is “rich” enough to manipulate parts, or whether the two constraints on the motion of the fence (pivot is fixed) overly constrain the set of reachable configurations of the part.

To be precise, we borrow definitions of reachable sets from nonlinear control theory (Sussmann [32]). A part’s configuration $\mathbf{q} = (x, y, \phi)^T$ is *controllable from* \mathbf{q} if, starting from \mathbf{q} , the part can reach every configuration in the configuration space. The part is *controllable to* \mathbf{q} if \mathbf{q} is reachable from every configuration. The part is *accessible from* \mathbf{q} if the set of configurations reachable from \mathbf{q} has nonempty interior in the configuration space.

We can also define local versions of these properties. The part is *small-time accessible from* \mathbf{q} if, for any neighborhood U of \mathbf{q} , the set of reachable configurations without leaving U has nonempty interior. The part is *small-time locally controllable from* \mathbf{q} if, for any neighborhood U of \mathbf{q} , the set of reachable configurations without leaving U contains a neighborhood of \mathbf{q} .

The phrases “from \mathbf{q} ” and “to \mathbf{q} ” can be eliminated in these definitions if they apply to the entire configuration space.

In these terms, if the configuration of the part is accessible, we know that the 1JOC has “enough” degrees of freedom: it can transfer the part from the initial configuration to a three-dimensional subset of the configuration space. Better yet, if the part is controllable, the 1JOC can transfer the part from any configuration to any other configuration. Small-time local controllability, an even stronger condition, implies that the part can follow any path arbitrarily closely. This is a useful property for repositioning parts under time and workspace constraints.

Although controllability and small-time local controllability guarantee the ability to feed parts, they are not absolutely necessary. The minimum we require of a parts feeding system is the feeding property: the

parts must be controllable to a single configuration from the set of initial configurations.

One way to reason about the controllability of a system is to write it as a system of drift and control vector fields and look at the dimension of the distribution defined by these vector fields. We can do this for an idealized model of the 1JOC (Section 2); however, this is difficult to do with the full pushing mechanics because the motion of a pushed object has no closed form. In addition, the motion of the part depends on the distribution of support forces between the part and the conveyor, which is usually unknown. The precise motion of the part is therefore unpredictable.

When we consider the full pushing mechanics in Section 3, we will limit our study to pushing motions with predictable outcomes. Despite this limited set of actions, we find that the 1JOC possesses the feeding property.

2 A Progression of Models

The 1JOC approach arises from a desire to explore the simplest mechanisms to accomplish a task. Planar objects have three degrees of freedom, suggesting the use of a robot with three or more actuated joints. However, it seems that two joints should suffice, by analogy with planar mobile robots. It is well known that a car can be arbitrarily positioned in the plane even if the steering wheel has only two settings. (For an introduction to motion planning for cars, and nonholonomic motion planning in general, see Latombe’s text [22].) Each setting of the steering wheel defines a rotation center of the car. In the case of the car these two rotation centers move with the car. To see that two *fixed* rotation centers suffice to produce arbitrary motions of the car, imagine that the car is fixed and the wheels drive the plane around.

Obviously a planar object cannot be moved to an arbitrary position using a single fixed rotation center. Thus one might conclude that two controlled freedoms are necessary. However, a drift field, plus a single controlled freedom, suffices.

The problem of pushing a part across a moving conveyor is complicated by the mechanics of pushing. Some insights can be gained by first considering an idealized model: the part matches the fence’s motion whenever desired, and matches the conveyor’s motion otherwise. In this section we examine a progression of models leading to the 1JOC system.

One Rotation Center First we consider an idealization of a rotating fence. We envision an infinite turntable to which the part can be affixed. This turntable can give the part an arbitrary angular veloc-

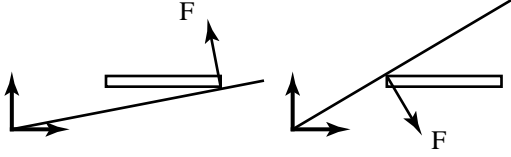

Figure 4: The thin rod is not small-time locally controllable from this configuration — it can only be rotated with a positive angular velocity.

ity about its pivot.

From any initial point in the part configuration space, the reachable set is one dimensional. If we consider the full pushing mechanics for a rotating fence, the reachable set is also just one dimensional. If the fence can swing all the way around and push on the other side, however, the part's configuration may be accessible. But we will not consider this case further.

Two Rotation Centers Now consider a pair of overlapping (yet independent) ideal turntables. At any given instant, the part is affixed to one of the two turntables and rotates about the center of that turntable. We assume that we can instantaneously switch the part from one turntable to the other.

There are two cases to consider:

- Both turntables are bidirectional. If each turntable can be driven in either forward or reverse, the situation is similar to driving a car with two different steering angles. As is well known, this system is small-time locally controllable and can approximate an arbitrary trajectory as closely as desired.
- One or both turntables are unidirectional. Now the situation is analogous to a car without reverse. The system is controllable, but not small-time locally controllable. It may be necessary to take a large excursion to accomplish a small motion.

We can model the conveyor as the limiting case of a turntable whose pivot approaches infinity. As above, the system is small-time locally controllable if both the turntable and conveyor are bidirectional, and it is simply controllable if either or both is unidirectional.

For this simple system, we can study controllability by considering the vector fields $X_1 = (0, 1, 0)^T$ and $X_2 = (-y, x, 1)^T$ corresponding to the conveyor and the turntable, respectively. When the part tracks the conveyor, the part motion is given by $\dot{\mathbf{q}} = vX_1$, where v is the velocity of the conveyor in the y direction. When the part tracks the turntable, the part motion is given by $\dot{\mathbf{q}} = \omega X_2$, where ω is the angular velocity of the turntable and the origin is at the center of the turntable.

The Lie bracket $[X_1, X_2]$ of these two vector fields is given by:

$$[X_1, X_2] = \frac{\partial X_2}{\partial \mathbf{q}} X_1 - \frac{\partial X_1}{\partial \mathbf{q}} X_2 = (-1, 0, 0)^T$$

The new vector field $[X_1, X_2]$ is linearly independent of X_1 and X_2 , yielding a third controlled freedom (provided both v and ω can be nonzero). The system therefore satisfies the Lie Algebra Rank Condition, and it is small-time accessible. If both the conveyor and the turntable are bidirectional (both v and ω can be positive or negative), the system is also small-time locally controllable (Nijmeijer and van der Schaft [27]). If either or both is unidirectional, the system is not small-time locally controllable, but it can be shown to be controllable by a simple constructive argument (Brockett [11]; Lynch and Mason [24]).

The 1JOC system consisting of a conveyor and a rotating fence resembles the system above with a unidirectional conveyor. One difference is that rotating the part about the pivot is only stable on a subset of the configuration space, specifically when an edge of the part is aligned with the fence.

Detailed Pushing Model We now consider pushing mechanics in the model with a conveyor and a rotating fence. We assume that the friction coefficient at the pushing contact and the distribution of support forces are known, and we place no restriction on the fence motions. Although this model makes unrealistic assumptions about the available information, any negative results will also apply to less detailed models.

Figure 4 shows that the system is not small-time locally controllable for the case of a thin rod. If the fence pushes from below, the rod's angular velocity is positive. If the fence swings around and pushes the part from above, the angular velocity is still positive. There is no maneuver combining these actions and conveyor drift that can locally achieve negative rotations.

Practical Pushing Models The detailed pushing model is difficult to use because it requires full knowledge of the pressure distribution. We can define more abstract models by restricting the allowable actions. In particular, we would like to use actions with predictable outcomes that do not impose unrealistic demands for information.

Any abstraction of the detailed pushing model will inherit its limitations, thus it is immediately clear that small-time local controllability is impossible.

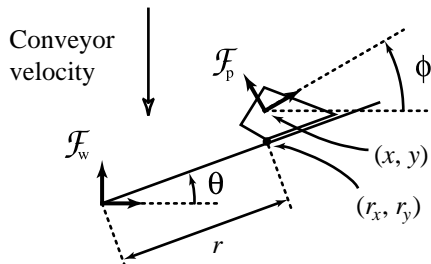

Figure 5: Notation.

3 The Feeding Property

In this section we focus on a particular model for the 1JOC and prove that it can transfer any polygonal part from any valid input configuration to a single goal configuration. To prove this property, we utilize a subset of the actions available to the 1JOC and show that they are sufficient to demonstrate the feeding property.

3.1 The 1JOC Model

The fence is a line that pivots about a fixed point on the line. The origin of a fixed world frame F_w coincides with the pivot point. The conveyor is the half-plane $x > 0$, with a constant drift velocity v in the $-y$ direction. The fence angle θ is measured with respect to the x axis of F_w , and its angular velocity is given by ω . The fence angular velocity ω is our single control input.

The part can be any polygon, but because the manipulator is a line, the part can always be treated as its convex hull. The center of mass of the part lies in the interior of the convex hull and the coefficient of friction between the fence and the part is nonzero. When we refer to a “part” in the rest of the paper, we assume these properties.

We assume quasistatic mechanics. As the fence pushes the part over the conveyor, the motion of the part in the world frame F_w is sufficiently slow that inertial forces are negligible compared to the frictional forces. The support friction acting on the part during pushing is determined by the motion of the part relative to the conveyor, not the world frame F_w .

It is convenient to represent the linear and angular velocity of the part relative to the conveyor in a frame F_p attached to the center of mass of the part. A velocity direction is simply a unit velocity vector. Velocity directions may also be represented as rotation centers in the frame F_p .

The configuration of the part frame F_p in the world frame F_w is given by $(x, y, \phi) \in \mathcal{R}^2 \times \mathcal{S}^1$. When an edge of the part is aligned with the fence, the contact radius r defines the distance from the fence’s pivot point to the closest point on the edge (the *contact ver-*

tex), and the configuration of the part can be given in the polar coordinates (r, θ) . The location of the point at r on the fence is (r_x, r_y) in the world frame. See Figure 5.

3.2 1JOC Primitives

We now describe the basic 1JOC primitives which yield the feeding property. We assume the fence is initially held at 0 degrees, perpendicular to the conveyor velocity, until the part contacts and comes to rest against the fence. See Figure 6 for an illustration of the primitives.

3.2.1 Stable Pushes

A stable push occurs when one edge of the part is aligned with the fence and the motion of the fence keeps the part fixed against it. The simplest example of a stable push occurs when the fence is held at 0 degrees, and a part on the conveyor drifts into contact and comes to rest on the fence. When the part is at rest, the fence is executing a stable push. The pushing direction, as seen by the part, is opposite the conveyor’s velocity direction.

Of course, a stable push may also occur while the fence is rotating. In a previous paper (Lynch and Mason [24]), we described the procedure *STABLE* that finds a set of stable pushing directions V_{stable} for a given pushing edge, pushing friction coefficient, and center of mass of the part. This set of pushing directions is fixed in the part frame F_p . The fence is guaranteed to execute a stable push if the edge is aligned with the fence and the motion of the fence and the conveyor combine to yield a pushing direction in V_{stable} . See Figure 7 for details.

For simplicity, we will only consider the edges of the part that yield a stable push while the fence is held at 0 degrees (the pushing direction is a translation normal to the edge). The existence of these stable edges is indicated by the following lemma (Lynch and Mason [24]):

Lemma 1 *All polygonal parts have at least one edge such that the normal translational pushing direction, along with a neighborhood of this pushing direction, belongs to V_{stable} . Such edges are called stable edges.*

Remark: The object may also have *metastable edges* — edges such that the center of mass lies directly above an edge endpoint when the fence is held at 0 degrees. If the fence rotates any nonzero amount in the “wrong” direction, the edge will become unstable. We will avoid these edges in this paper. If the part initially

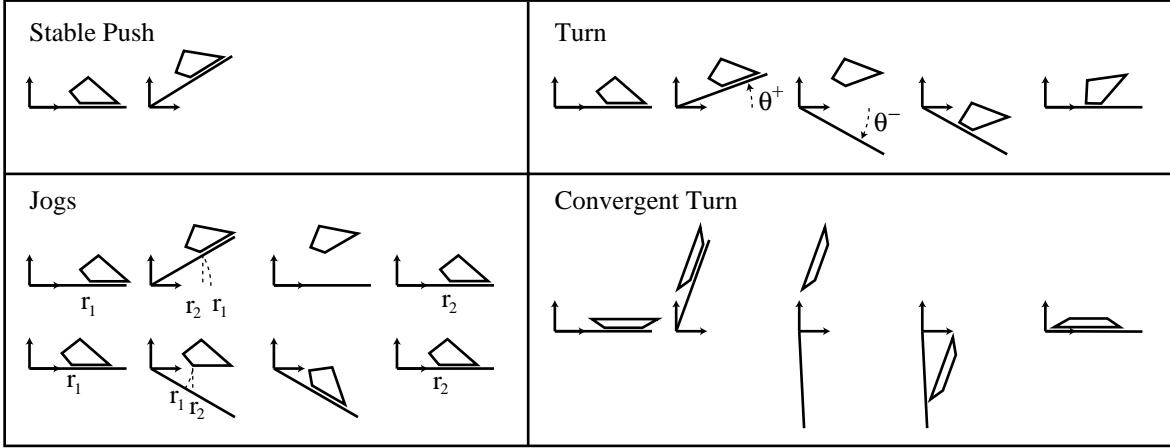

Figure 6: Step by step illustrations of the IJOC primitives.

comes to rest on the fence on one of these edges, we can perturb the fence slightly to bring the part to a stable edge.

Lemma 1 says that a stable edge is also stable for a neighborhood of fixed fence angles around 0 degrees. In addition, if the contact radius r is sufficiently large, the fence pivot will be inside the set of stable rotation centers V_{stable} fixed in the part frame F_p . If the fence angular velocity ω is large enough relative to the conveyor velocity v , the combined pushing motion is nearly a pure rotation about the pivot, and the pushing motion is stable. Therefore, it is possible to stably push the part from any θ_0 to any θ_1 in a counterclockwise (CCW) direction, where $90^\circ > \theta_1 > \theta_0 > -90^\circ$. Figure 8 illustrates a method for finding the *minimum stable radius*: the minimum contact radius r such that the push is stable for all fence angles in the range $[-90, 90]$ for a given fence angular velocity ω and conveyor velocity v .

For a push to be stable when the fence is rotating CCW, the contact radius r must be sufficiently large. We can change r by performing jogs, described below.

3.2.2 Jogs

Jogs are simple maneuvers that allow us to change the contact radius r from the fence pivot to the part without changing the stable resting edge.

Lemma 2 *A part resting on a stable edge can be moved from any initial contact radius r on the fence to any desired r in the range $(0, \infty)$ by a series of jogs.*

Proof: We use the fact that a neighborhood of pushing directions about the normal translation is stable for a stable edge. In fact, there is a range $[\theta^{min}, \theta^{max}]$ of fixed fence angles about 0 degrees that are also stable.

The fence does not have to be motionless to execute a stable push, however; if the fence angular velocity ω is small enough with respect to the conveyor velocity v , then the fence can execute a stable push while moving in the angle range $[\theta^{min}, \theta^{max}]$, regardless of the contact radius r .

To decrease the contact radius r , the fence is raised to an angle θ^+ ($\theta^{max} \geq \theta^+ > 0$), keeping the part fixed to the fence by a stable push. This changes the value of r_x to $r_x \cos \theta^+$. The fence then drops to 0 degrees, immediately releasing the part. The part drifts back into contact with the fence and settles on the same stable edge. We assume there is no slip between the part and the fence. (The no-slip assumption is important for open-loop feeding plans.) The result of the jog is to decrease the contact radius from r to $r \cos \theta^+$.

To increase the contact radius r , the fence is quickly lowered to an angle θ^- ($\theta^{min} \leq \theta^- < 0$), releasing the part. The part drifts back into contact with the fence and settles on the same stable edge. The fence is then raised to 0 degrees again, pushing the part with a stable push. The contact radius of the part has changed to $r / \cos \theta^-$.

A series of jogs, either increasing or decreasing r , can bring the part to any r in the range $(0, \infty)$. \square

A jog is directly analogous to the Lie bracket motion for the ideal turntable plus conveyor system analyzed in Section 2. The difference from the ideal system is that the part only tracks the fence when it is in stable contact. Nonetheless, we can now show that the configuration of the part is accessible with just stable pushes, jogs, and the conveyor drift.

Theorem 1 *The configuration of a polygonal part in stable edge contact with a fence held at 0 degrees is small-time accessible using stable pushes, jogs, and conveyor drift.*

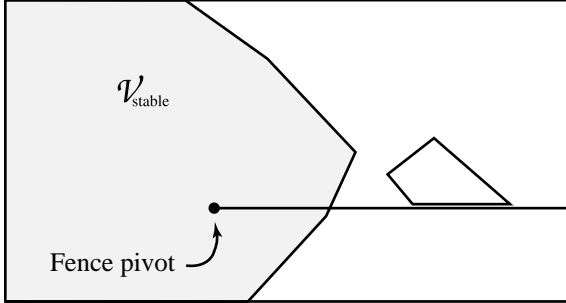

For a given edge contact, we can determine V_{stable} , the set of pushing rotation centers that keep the object fixed to the pusher. Note that V_{stable} is fixed in the part frame, not the world frame.

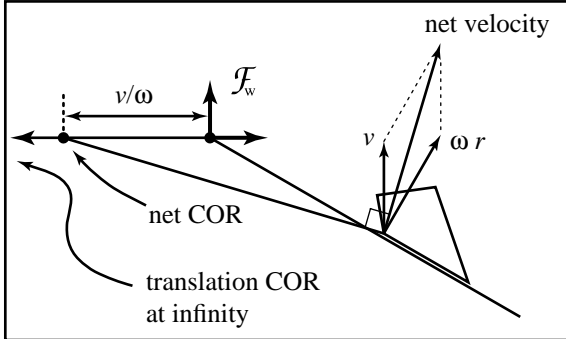

The conveyor velocity v and the rotational velocity ω about the fence pivot combine to form a net velocity at each point. This can be expressed as a net center of rotation (COR), which lies on the line through the fence pivot and perpendicular to the conveyor velocity.

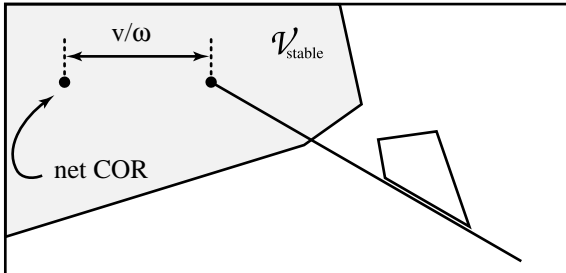

Provided the net COR is contained in V_{stable} , the part will remain stationary with respect to the fence for that combination of conveyor and fence velocities. Note that as the fence rotates, the conveyor velocity changes direction with respect to the part, and the net COR rotates about the fence pivot at a radius of v/ω .

Figure 7

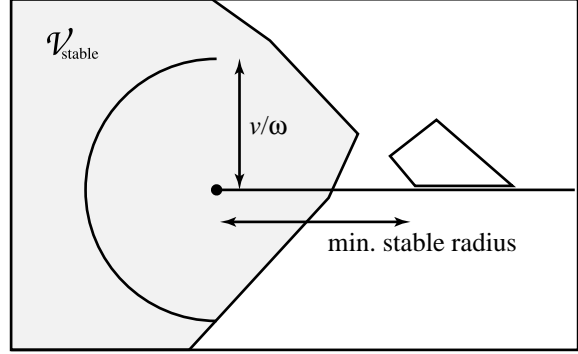

Figure 8: The locus of net COR form a semicircle about the fence pivot as the fence swings from -90 to 90 degrees. Given a fence angular velocity ω and a conveyor velocity v (which determine the radius of this semicircle), we pick a minimum stable radius so that this semicircle lies completely within V_{stable} . Recall that V_{stable} is fixed with respect to the part, so increasing the contact radius moves the semicircle deeper into V_{stable} . This conservative estimate of the minimum stable radius guarantees stable pushing in the counterclockwise direction at any fence angle in $[-90^\circ, 90^\circ]$.

Proof: Given any neighborhood of the part configuration while it is in stable edge contact with the fence at 0 degrees, it is possible to jog the part a nonzero distance in both directions without leaving this neighborhood. The effect of the jog is to change the x coordinate of the part configuration, exactly like the Lie bracket motion of Section 2. The other two vector fields of Section 2 can be obtained directly by conveyor drift and stable pushes. \square

We call I the set of initial part configurations that drift to stable edge contact with the fence at 0 degrees. From a stable edge contact, Theorem 1 indicates that the configuration of the part is small-time accessible. Therefore, the configuration of the part is accessible from the set I .

We still have not proven the feeding property. To get this property, we need the ability to turn a part to a new stable edge.

3.2.3 Turns

Turns allow us to change the edge of the part aligned with the fence, subject to the constraint that the initial and final edges both be stable edges. A turn consists of raising the fence to an angle $\theta^+ \geq 0$ by executing a stable push; dropping the fence to an angle $\theta^- \leq 0$, immediately releasing the part; and reacquiring the part on the new edge with a stable push, raising the fence back to 0 degrees. The final push commences at the moment the new edge contacts the fence.

Lemma 3 Any polygonal part has at most one stable edge from which it is impossible to turn the part to the

next CW stable edge. Exception: a part has two such stable edges if they are the only stable edges and they are parallel to each other.

Proof: The fence can execute a stable push to any angle less than 90 degrees, and it can reacquire the part with a stable push at any angle greater than -90 degrees. This indicates that it is possible to reach any final stable edge less than 180 degrees CW of the initial edge. If the part has two or more stable edges, there can only be one stable edge from which the next CW stable edge is greater than 180 degrees removed. For “exception” parts, there are two stable edges which are exactly 180 degrees removed from each other. \square

There are a few important points to make about turns:

- The contact radius r , for both the initial and final edges, must be large enough that the pushing directions always remain in V_{stable} .
- The quantity $\theta^+ - \theta^-$ is determined by the part geometry, but the actual values of θ^+ and θ^- are not. To some extent, the contact radius r after the turn can be controlled by the choice of these values. If the angle difference between the initial and final edge is 90 degrees or more, r can be changed to any value in the range $(0, \infty)$ during the turn.
- This primitive requires precise knowledge of the conveyor’s motion — the final stable push must begin precisely when the new edge contacts the fence.

Consider the case where turning a part to a new stable edge requires raising the fence to $90 - \delta$ and catching the part at $-90 + \epsilon$, where δ and ϵ are small positive values. It may be necessary to move the part to a large contact radius r before executing the turn to ensure that the part remains completely on the conveyor ($x > 0$) during the initial push.

3.2.4 Convergent turns

To perform a turn between two stable edges which are parallel, the fence must, in principle, be raised to 90 degrees, pushing the part off the conveyor. To turn such parts, we can introduce a convergent turn: raise the fence to $90 - \delta$, allow the part to drift down, and begin pushing it again at $-90 + \epsilon$. Assuming no slip at the pushing contact, the part will converge to the new stable edge as the fence is raised to 0 degrees. Convergent turns allow us to strengthen Lemma 3 to apply to all polygonal parts, with no exceptions. In this paper,

the sole function of convergent turns is to handle parts with only two stable edges, which are parallel.

3.3 The Feeding Property

Using the lemmas proven above, we can now demonstrate the feeding property for the 1JOC.

Theorem 2 *The 1JOC possesses the feeding property:*

- for all polygonal parts
- for the three-dimensional space I of initial configurations such that the part initially comes to rest on a stable edge, completely on the conveyor, against the fence fixed at 0 degrees, and
- using only stable pushes, jogs, turns, convergent turns, and conveyor drift.

Furthermore, the goal configuration can be chosen from a three-dimensional subset of the configuration space.

Proof: If the part has a stable edge such that it cannot be turned to a new stable edge, then this edge must be chosen as the goal edge. Otherwise, any stable edge can be chosen as the goal edge. By Lemma 3 (strengthened by the convergent turn of Section 3.2.4), this goal edge can be reached using turns. Once at the goal edge, the part can be jogged to any contact radius r in the range $(0, \infty)$ (Lemma 2). By Lemma 1, the part is stable against the fence for a range of fence angles θ . The goal edge therefore allows a two-dimensional set of final stable configurations of the part in the (r, θ) space. If the fence is quickly lowered to 90 degrees, releasing the part, this set drifts to a set of reachable configurations with nonempty interior in the world configuration space. Any configuration in this set can be chosen as the goal. \square

If the application of the 1JOC is to stuff parts into a feeder track, then the fence can be rotated 90 degrees, pushing the part off the conveyor into the feeder track, instead of releasing it to continue on the conveyor.

4 A Feeding Planner

The feeding property means that there exists a sequence of jogs and turns to feed any polygonal part, assuming infinite fence length and an infinite conveyor half-plane. A 1JOC with finite fence and conveyor dimensions may not be able to feed some parts. For a given part however, we can always find a fence and conveyor with finite dimensions to feed it. We describe how to find a sequence of jogs and turns to feed

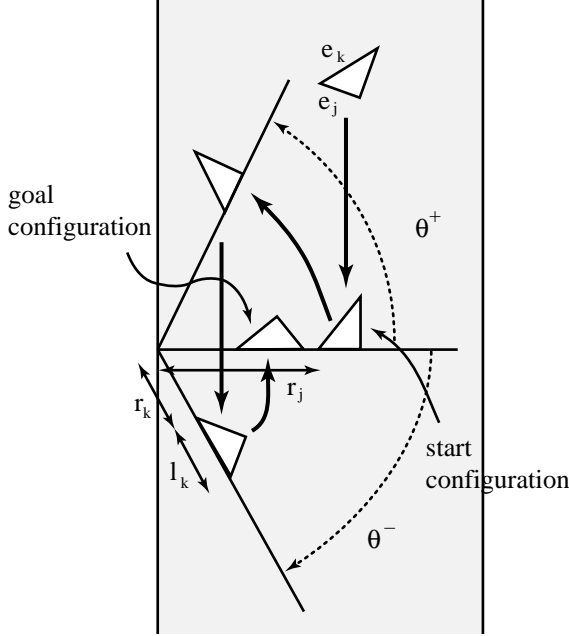

Figure 9: A feeding plan to move a triangle from start configuration (e_j, r_j) to goal configuration (e_k, r_k) by a turn with raise and drop angles of θ^+ and θ^- . Length of edge e_k is l_k .

a given part with a fence and conveyor of known dimensions in the minimum amount of time.

We assume that we know the shape and center of mass of the part, the coefficient of friction between the fence and part, the conveyor velocity, and the fence and conveyor dimensions. The coefficient of friction between the part and conveyor is assumed constant, and we pick the fence angular velocity to be one of three discrete values: ω_{stable} (for stable pushes), ω_{drop} (when lowering the fence), and zero. We assume the fence receives parts that are singulated.

A part drifts down the conveyor until it comes to rest against the fence. The feeding problem consists of getting the part from this start configuration to the goal configuration (see Figure 9), where the configurations are specified by the edge aligned with the fence, and the contact radius (distance from pivot to the closest vertex of the resting edge). We assume that the initial fence orientation is zero, and, for convenience, that the final fence orientation is zero as well.

Turns change the part orientation; they rotate the part CCW so the new edge aligned with the fence is CW to the initial edge. Turns thus enable transitions to stable edges in the CW direction. We consider all CW sequences of edges beginning at the start edge e_s and ending at the goal edge e_g which do not require rotating the part more than 360 degrees. Take an example sequence $S = \{e_s, e_j, e_k, e_g\}$. If we can find a valid sequence of jogs and turns to move the part in

sequence through the edges in S and change the contact radius by the required amount, we have a feasible plan. Of all feasible plans, we take the one which requires minimum time.

4.1 A Simple Example

Consider a part resting on edge e_j (orientation ϕ_j) at radius r_j which is to be moved to the neighboring CW stable edge e_k (orientation ϕ_k) at radius r_k (see Figure 9). Here the sequence of edges is $S = \{e_j, e_k\}$. We look for a feasible solution (and ignore minimizing the time). Assume r_j and r_k are greater than the minimum stable radii for the corresponding edges, and are close enough in magnitude that no jog is required. Here, finding a plan consists of determining the fence angles θ^+ and θ^- for the turn. From the geometry, we have:

$$r_k = r_j \frac{\cos \theta^+}{\cos \theta^-} - l_k \quad (1)$$

$$\theta^+ - \theta^- = \phi_k - \phi_j \quad (2)$$

Solving these equations, we find:

$$\theta^- = \tan^{-1} \left(\cot(\phi_k - \phi_j) - \frac{r_k + l_k}{r_j \sin(\phi_k - \phi_j)} \right) \quad (3)$$

$$\theta^+ = \phi_k - \phi_j + \theta^- \quad (4)$$

This simple example has a closed form solution that provides us with a plan. (Note that when $(\phi_k - \phi_j) \geq 90$, the radius change can be arbitrarily large or small.)

4.2 Nonlinear Programming Approach

For the general case, we must find a sequence of jogs and turns that effects the desired configuration change and minimizes time. For a given sequence of edges, we must determine the parameters for each turn while ensuring that each contact edge in a turn has a contact radius that is no less than its minimum stable radius. If the contact radius is less than the minimum radius, we must translate the part prior to executing the turn. Such a *translation* may consist of a jog or a series of jogs.

A feeding plan to transfer a part from its start configuration (e_s, r_s) to its goal configuration (e_g, r_g) consists of several stages, each of which accomplishes an edge transition. Each stage consists of a translation followed by a turn; the translation for a given stage may be zero. A plan with the edge transition sequence S will take $n - 1$ stages, where $n = |S|$. A final translation may also be required after the goal edge has been reached.

Consider the i th stage in a plan (see Figure 10) to accomplish the transition from edge e_j to edge e_k . First, we perform a translation of g_i , which moves the part to

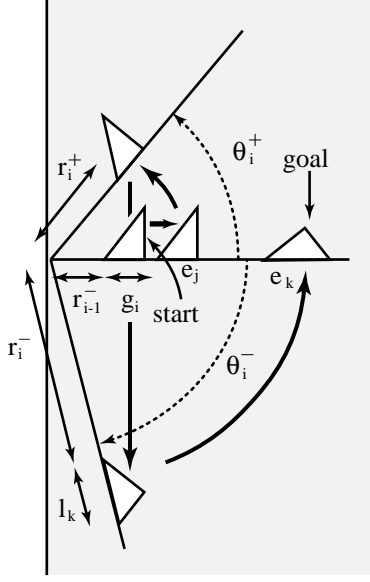

Figure 10: The i th transition from edge e_j to edge e_k with a translation of g_i , start and end turn radii r_i^+ and r_i^- , and raise and drop angles θ_i^+ and θ_i^- .

a contact radius of r_i^+ . Since we are about to perform a turn, this radius must be greater than the minimum stable radius for edge e_j , r_j^{stable} . We then perform a turn with a raise angle of θ_i^+ and a drop angle of θ_i^- . The stable push at the end of the turn brings the fence to $\theta = 0$ with the new contact edge e_k . For this stable push on edge e_k , the contact radius r_i^- must be greater than the minimum stable radius for e_k , r_k^{stable} . We also have to ensure that the fence raise and drop angles are in valid ranges, that the part is within fence and conveyor bounds, and that the fence contacts the part only at the end of the drift phase.

Assume the fence pivot is on the conveyor left edge, and that the conveyor half-length exceeds its width, which exceeds the fence length. The resulting constraints are (for $i = 1, \dots, n-1$):

$$r_i^+ = r_{i-1}^- + g_i \quad (5)$$

$$r_i^- = \frac{(r_i^+ - d_j) \cos \theta_i^+}{\cos \theta_i^-} - (l_k + d_k) \quad (6)$$

$$\theta_i^+ - \theta_i^- = \phi_k - \phi_j \quad (7)$$

$$r_j^{max} \geq r_i^+ \geq r_j^{stable} \quad (8)$$

$$r_k^{max} \geq r_i^- \geq r_k^{stable} \quad (9)$$

$$90 > \theta_i^+ \geq 0 \quad (10)$$

$$0 \geq \theta_i^- > -90 \quad (11)$$

$$(r_i^+ + a_j^v) \cos \theta_i^+ - p_j^v \sin \theta_i^+ > 0, \forall v \in V \quad (12)$$

$$\omega_{drop} r_i^+ \cos \theta_i^+ > v_c \quad (13)$$

$$\frac{(r_i^+ - d_j) \sin \theta_i^+ - (r_i^- + l_k + d_k) \sin \theta_i^-}{v_c} > \frac{\theta_i^+ - \theta_i^-}{\omega_{drop}} \quad (14)$$

where l_k is the length of edge k , ϕ_j and ϕ_k are the orientations of edges e_j and e_k , v_c is the conveyor velocity, r_j^{max} and r_k^{max} are maximum valid contact radii for edges e_j and e_k , V is the set of part vertices, and a_j^v and p_j^v are the components along and perpendicular to edge e_j of the vector from the contact vertex to a part vertex v . If e_j and e_k are neighboring edges, $d_j = d_k = 0$. Else, d_j and d_k are the distances from the (virtual) intersection vertex of (extended) edges e_j and e_k to the contact vertices of these edges.

The start and goal constraints are:

$$r_0^- = r_s \quad (15)$$

$$r_g = r_{n-1}^- + g_n \quad (16)$$

These define a set of nonlinear constraints over the variables g_i , θ_i^+ , θ_i^- , r_i^+ , and r_i^- . (We could also eliminate the equality constraints and solve for fewer variables.) Since the radius at the start of a turn depends on the radius at the end of the previous turn, an optimal solution must consider all variables simultaneously.

We want a solution which minimizes the total time to feed the part. The time taken for each stage of the plan is the sum of the jog time, fence raise time, drift time on the conveyor, and fence recovery time. We approximate the total time by the objective function we minimize:

$$t_n g_n^2 + \sum_{i=1}^{n-1} \left[t_i g_i^2 + \frac{\theta_i^+}{\omega_{stable}} - \frac{\theta_i^-}{\omega_{stable}} + \frac{(r_i^+ - d_j) \sin \theta_i^+ - (r_i^- + l_k + d_k) \sin \theta_i^-}{v_c} \right] \quad (17)$$

The approximate time cost coefficient of the i th jog series is $t_i = k \cos \alpha_i / v_c (r_i^+ + r_{i-1}^-)$ where k is a constant chosen to be 1000, and $\alpha_i = \min(|\theta_i^{min}|, |\theta_i^{max}|)$ is a safe jog angle for the i th jog series.

Our problem as stated above is a nonlinear programming problem whose feasible solutions yield valid feeding plans. (See Bazaraa and Shetty's text [4] for an introduction to nonlinear programming.) Once we have a solution for the g_i , θ_i^- , θ_i^+ , r_i^+ , and r_i^- values which satisfies the constraints (5)–(16) and minimizes our objective function, we must still determine a series of jogs to execute the translations g_i .

An inward translation distance $g_i < 0$ requires a series of decreasing jogs, such that $r_i^+ = r_{i-1}^- (\cos \gamma_i)^m \cos \rho_i$ where m is a non-negative

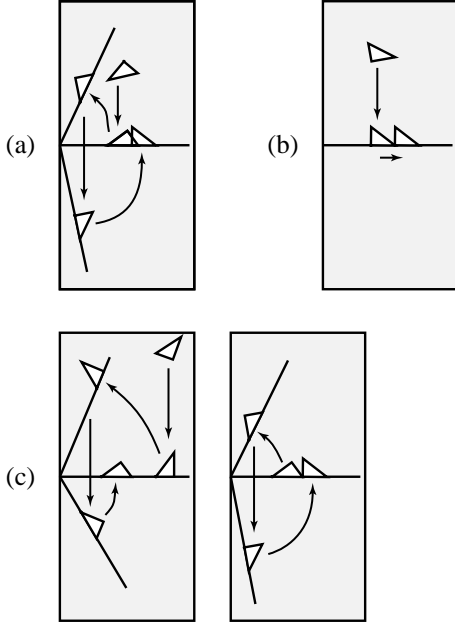

Figure 11: Example feeding plans for a triangle. The goal configuration ($\phi_g = 269.34, r_g = 150$) is the same, while the start configurations are different: (a) ($\phi_s = 126.49, r_s = 100$) (b) ($\phi_s = 269.34, r_s = 100$) (c) ($\phi_s = 0, r_s = 200$).

integer, and $\theta_i^{max} \geq \gamma_i \geq \rho_i \geq 0$. So this radius decreasing translation is accomplished by a series of m jogs of angle γ_i followed by a jog of ρ_i . Similarly, an outward translation distance $g_i > 0$ requires a series of increasing jogs, such that $r_{i-1}^- = r_i^+ (\cos \gamma_i)^m \cos \rho_i$ where m is a non-negative integer, and $0 \geq \rho_i \geq \gamma_i \geq \theta_i^{min}$.

A feasible solution to the above problem always exists if the fence and conveyor are large enough that each stable edge has a valid contact radius greater than its minimum stable radius. When this condition is satisfied, a plan with a maximum of three stages to get the part from the start to the goal configuration exists, although it may not be optimal.

4.3 Generating Feeding Plans

We now outline the process of generating feeding plans. From the part description and coefficient of friction, we compute the minimum stable radii for the stable edges and the transition angles between these edges. For the start and goal configurations, we generate candidate edge transition sequences. For each such sequence, the corresponding objective function and constraints are input to a commercial nonlinear programming package called GINO [23] to solve the problem. A feasible solution to the nonlinear programming formulation provides us with a valid feeding plan. See the example plans in Figure 11.

Currently we use minimum stable radius values empirically determined to be robust. A conservative esti-

mate of the minimum stable radius can be determined as illustrated in Figure 8. Also, the planning procedure can be extended to use convergent turns to handle parts with only two stable edges which are parallel.

5 Implementation

We have implemented several feeding plans on a conveyor with the fence being (somewhat ironically) actuated by one joint of an Adept 550 SCARA robot. The conveyor speed and fence rotational speed have been selected to be 20 mm/s and 30 degrees/s respectively. The fence is covered with a foam material to avoid slip between the part and the fence.

Currently we place the part at the start configuration and observe the position of the part after plan execution. In a fully implemented setup, singulated parts would come down the conveyor in random configurations. The initial part orientation and contact radius would be determined by an overhead camera, and a feeding plan to get the part to the goal configuration without any further sensing would be generated.

Figure 11 illustrates three plans we ran on our setup which achieve the same goal configuration from different starting configurations. Plan (a) requires a single turn to reach the goal, plan (b) requires just a translation, and plan (c) requires two turns. These plans had position errors at the goal configuration ranging from 0 mm to 3 mm. The errors are sensitive to part shape measurements, fence turn angles, and timing in the turns. Occasional slip also causes some error.

6 Variations on a Theme

The IJOC approach uses a fixed velocity conveyor in combination with a single servoed joint to obtain the diversity of motions required for planar manipulation. We have shown by proof and demonstration that the IJOC is capable of useful planar manipulation: any polygon is controllable from a broad range of initial configurations to any goal chosen from a broad range of goal configurations.

For this paper we designed the system and the set of actions to simplify analysis and planning. There are many variations on the approach which may be more suitable in different contexts. Some variations on the system configuration are: a curved fence; a prismatic fence in place of the involute fence; a rotary table in place of the conveyor; or use of gravity rather than a conveyor. Some variations on the actions are: optimization of fence rotation rates instead of using fixed values; allowing objects to slip along the fence; complete revolutions of the object to reduce

jogs; and speeds high enough to require dynamic analysis instead of quasi-static. Another variation would be to use techniques similar to Bicchi and Sorrentino's to roll objects on the belt [5].

When addressing potential industrial applications, it is important to consider the whole system, including interactions with surrounding equipment. Several different scenarios have occurred to us: a IJOC to pose objects followed by a simple pick-and-place device; a IJOC to singulate parts for a SCARA; or two or three IJOCs pipelined to singulate and feed parts.

Acknowledgments

Many thanks to Costa Nikou for the implementation of this work on the Adept robot. We thank Mike Erdmann, Garth Zeglin, and Nina Zumel for early discussions about this paper. We thank Adept, NSK, and SONY for helping us learn about automation and for making equipment available. This work was supported by ARPA and NSF under grant IRI-9318496.

References

- [1] S. Akella and M.T. Mason. Posing polygonal objects in the plane by pushing. In *IEEE Int. Conf. on Robotics and Automation*, 1992, pp. 2255–2262.
- [2] H. Arai and S. Tachi. Position Control of a Manipulator with Passive Joints Using Dynamic Coupling. *IEEE Trans. on Robotics and Automation*, vol. 7, no. 4, August 1991, pp. 528–34.
- [3] H. Arai and O. Khatib. Experiments with Dynamic Skills. In *Proceedings of the 1994 Japan-USA Symposium on Flexible Automation*, pp. 81–4.
- [4] M.S. Bazaraa and C.M. Shetty. *Nonlinear Programming: Theory and Algorithms*. John Wiley and Sons, 1979.
- [5] A. Bicchi and R. Sorrentino. Dexterous Manipulation Through Rolling. In *IEEE Int. Conf. on Robotics and Automation*, 1995.
- [6] K.F. Böhringer, V. Bhatt, and K.Y. Goldberg. Sensorless Manipulation Using Transverse Vibrations of a Plate. In *IEEE Int. Conf. on Robotics and Automation*, 1995.
- [7] K. Böhringer, R. Brown, B. Donald, J. Jennings, and D. Rus. Distributed Robotic Manipulation: Experiments in Minimalism. In *International Symposium on Experimental Robotics*, 1995.
- [8] G. Boothroyd, C. Poli, and L.E. Murch. *Automatic Assembly*. Marcel Dekker, 1982.
- [9] G. Boothroyd. *Assembly Automation and Product Design*. Marcel Dekker, 1992.
- [10] D.L. Brock. Enhancing the Dexterity of a Robot Hand Using Controlled Slip In *IEEE Int. Conf. on Robotics and Automation*, 1988, pp. 249–251.
- [11] R.W. Brockett. Nonlinear Systems and Differential Geometry. *Proceedings of the IEEE*, vol.64, no. 1, January 1976.
- [12] M. Brokowski, M. Peshkin, and K. Goldberg. Curved Fences for Part Alignment. In *IEEE Int. Conf. on Robotics and Automation*, 1993, pp. 3:467–473.
- [13] R.C. Brost. Dynamic Analysis of Planar Manipulation Tasks. In *IEEE Int. Conf. on Robotics and Automation*, 1992, pp. 2247–54.
- [14] M. Caine. The Design of Shape Interactions Using Motion Constraints. In *IEEE Int. Conf. on Robotics and Automation*, 1994.
- [15] A.D. Christiansen. Manipulation Planning from Empirical Backprojection In *IEEE Int. Conf. on Robotics and Automation*, 1990, pp. 762–768.
- [16] A.D. Christiansen, A.D. Edwards, and C.A. Coello. Automated Design of Parts Feeders using a Genetic Algorithm. Submitted to the 1996 *IEEE Int. Conf. on Robotics and Automation*.
- [17] P.E. Crouch. Spacecraft Attitude Control and Stabilization: Applications of Geometric Control Theory to Rigid Body Models. *IEEE Trans. on Automatic Control*, vol. 29, no. 4, 1984, pp. 321–31.
- [18] M.A. Erdmann and M.T. Mason. An exploration of sensorless manipulation. *IEEE Trans. on Robotics and Automation*, 4(4):369–379, Aug. 1988.
- [19] M. Erdmann. An Exploration of Nonprehensile Two-Palm Manipulation: Planning and Execution. *The Seventh International Symposium on Robotics Research*, 1995.
- [20] K.Y. Goldberg. Orienting polygonal parts without sensors. *Algorithmica*, 10:201–225, 1993.
- [21] H. Hitakawa. Advanced Parts Orientation System Has Wide Application. *Assembly Automation*, vol. 8, no.3, 1988, pp. 147–50.
- [22] J.C. Latombe. *Robot Motion Planning*. Kluwer Academic Publishers, 1991.
- [23] J. Liebman, L. Lasdon, L. Schrage, and A. Waren. *Modeling and Optimization with GINO*. The Scientific Press, 1986.
- [24] K.M. Lynch and M.T. Mason. Controllability of Pushing. In *IEEE Int. Conf. on Robotics and Automation*, 1995.
- [25] K.M. Lynch and M.T. Mason. *Nonprehensile Manipulation*. Carnegie Mellon University, Robotics Institute videotape, 1995.
- [26] M. Mani and W. Wilson. A Programmable Orienting System for Flat Parts. In *North American Manufacturing Research Institute Conference XIII*, 1985.
- [27] H. Nijmeijer and A.J. van der Schaft. *Nonlinear Dynamical Control Systems*. Springer-Verlag, 1990.
- [28] G. Oriolo and Y. Nakamura. Control of Mechanical Systems with Second-Order Nonholonomic Constraints: Underactuated Manipulators. In *Proceedings of the 30th Conference on Decision and Control*, 1991, pp. 2398–2403.
- [29] M.A. Peshkin and A.C. Sanderson. Planning Robotic Manipulation Strategies for Workpieces That Slide. *IEEE Journal of Robotics and Automation*, vol. 4, no. 5, October 1988, pp. 524–31.
- [30] A. Rao, D. Kriegman, and K. Goldberg. Complete Algorithms for Reorienting Polyhedral Parts using a Pivoting Gripper. In *IEEE Int. Conf. on Robotics and Automation*, 1995, pp. 2242–8.
- [31] O.J. Sjørdalen, Y. Nakamura, and W.J. Chung. Design of a Nonholonomic Manipulator. In *IEEE Int. Conf. on Robotics and Automation*, 1994, pp. 8–13.
- [32] H.J. Sussmann. Lie brackets, real analyticity and geometric control. In *Differential Geometric Control Theory*, Brockett, Millman, and Sussman, eds. Birkhauser, 1983.
- [33] P.J. Swanson, R.R. Burrige, and D.E. Koditschek. Global asymptotic stability of a passive juggler: A parts feeding strategy. In *IEEE Int. Conf. on Robotics and Automation*, 1995, pp. 1983–1988.